



AACER

SPORTS FLOORING

TriPower® Pad

The next generation in a sports performance pad, Aacer's new TriPower® Pad provides EN, and DIN certified performance with increased load handling. The TriPower® Pad's unique, wide stance gives greater response consistency and lower vibration than other pad designs.



Sweets.com



ACCESSORY



TriPower® Pad



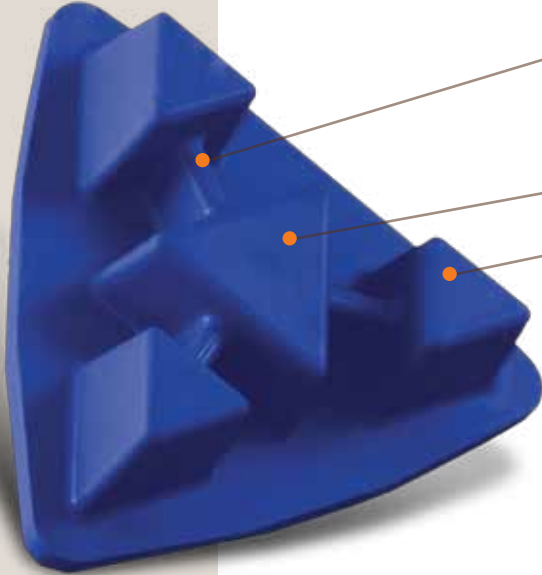

TriPower® Pad offers superior shock absorption and vibration dampening. The unique blend of EPDM ensures stability and longevity required by high performance floors.

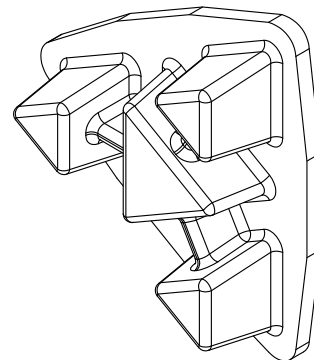
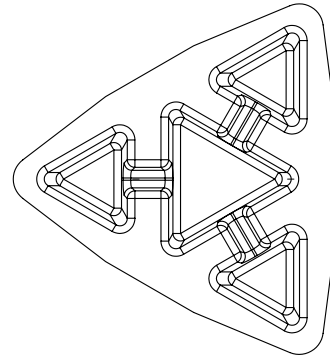

- ① Structural Webs - Cross Linked
 - a. Greater load carrying ability
 - b. Vibration attenuation
 - c. Increased uniformity & consistency in response
- ② Stage II heavy duty load distribution
- ③ 3 point surface contact shock pads - Athletic resilience

DETAIL DRAWINGS



Composition	EPDM Rubber / can be recycled 
Hardness	Shore A
ASTM Durometer	50 - Blue 55 - Green 60 - Orange 70 - Red
Thickness	¾" (19mm) & ½" (12mm)
Triangular Footprint	3point primary surface contact 1point secondary load contact
ASTM D412 Tensile PSI	1810
ASTM D412 Elongation	648
Loading	Excellent
Performance Info	   Tested to meet DIN 18032 Part II Tested to meet EN 14904 Tested to meet M.F.M.A.'s pur standards ASTM 2137 low temperature brittleness, 3 min @ -40 - pass ASTM D395 compression set, 22 hours @ 70c set % -20
U.S. Patent	#598,8915

Aacer Pad Options

TriPower® Green  ½"	TriPower® Red  ¾"	TriPower® Orange  ¾"	EcoDIN  7/16"	AacerCush  ¾"	AacerFlex  ¾"
--	--	---	--	--	--

AacerFlooring.com

(877) 582-1181

It is the policy of Aacer Flooring to continuously improve its line of products. Therefore, Aacer Flooring reserves the right to change, modify or discontinue systems, specifications and accessories of all products at any time without notice or obligation to purchaser.